

Operating Instructions Helical Gear Motors Series M/N

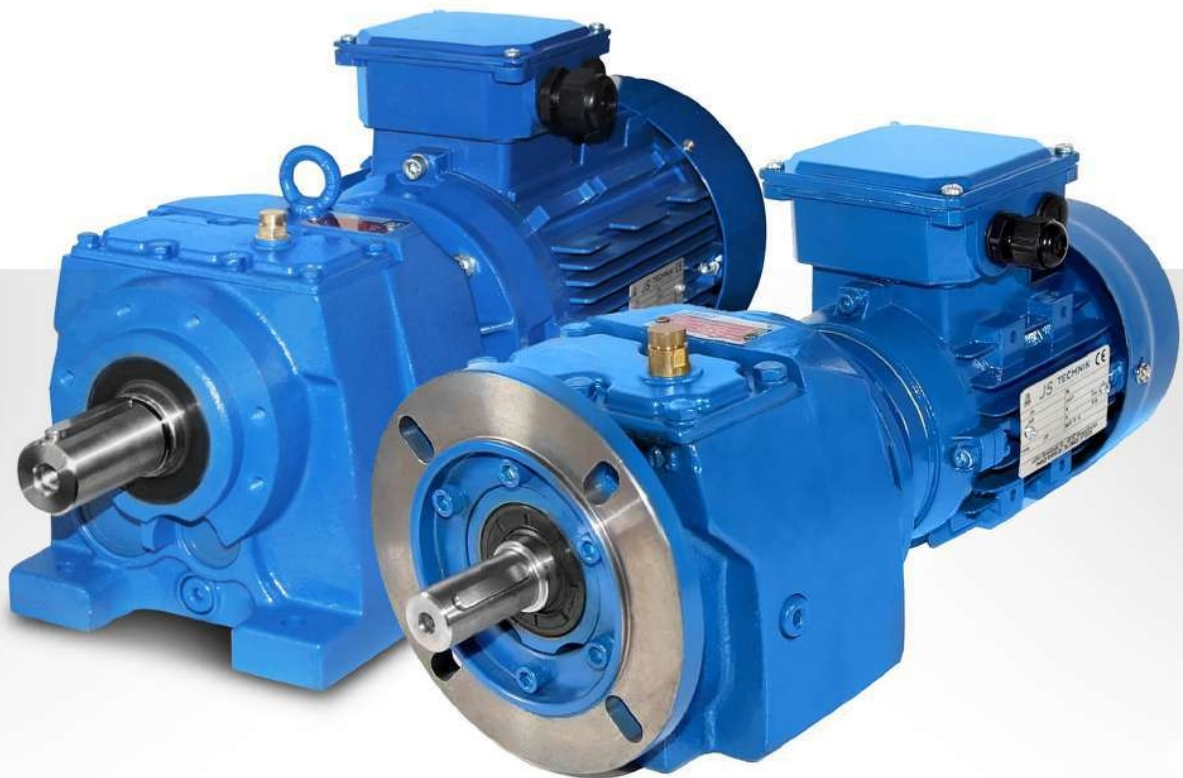



Content	02
1- How to Use This Manual	04
2- Unit Designation	05
2.1- Detailed Unit Designation.....	05
2.2- Nameplate, Unit Designation.....	06
3- Standard Type Gearbox Parts List	07
3.1- M Type 3 Stages.....	07
3.2- N Type 3 Stages.....	08
3.3- M, N... Additional Stage for 4 Stage Types.....	09
3.4- M, N... Motor Flange for Direct Coupled Types.....	10
3.5- M, N... Types B5, B14 Motor Flange.....	10
3.6- M, N Types... Input Bearing Housing with Solid Input Shaft.....	10
4- Safety	11
4.1- Intended Use.....	11
4.2- Improper Use.....	11
4.3- Safety Instructions.....	12
4.3.1- General Safety Instructions.....	12
4.3.1.1- Working on the Gear Unit.....	12
4.3.1.2- Operation.....	12
4.3.1.3- Maintenance.....	12
4.3.1.4- Lubricant.....	12
4.3.1.5- Ambient Conditions.....	12
4.4- Tightening Torques.....	13
4.5- In Case of Fire.....	13
4.5.1- Suitable Extinguishing Agents.....	13
4.5.2- Unsuitable Extinguishing Agents.....	13
5 - Things to Check	14
5.1- Transportation.....	14
5.2- Storage.....	15
6- Installing the Gear Unit	15
6.1- Before You Start.....	15
6.2- Checking Shaft Dimensions.....	16
6.3- Checking Ambient Temperatures.....	16
6.4- Checking Voltage Supply.....	16
6.4.1 Standard Circuit Diagrams for Electric Motors.....	17
6.4.2 Standard Circuit Diagrams for Brake Motors.....	18



6.5- Checking Mounting Position.....	19
6.6- How to Use Breather Plug.....	19
6.7- Checking Oil Level	19
6.8- Checking Shaft Ends and Mounting Faces	19
6.9- Protection from Corrosive Environment	19
6.10- Checking Accessibility to Oil Plugs	20
7- Mechanical Installation	20
7.1- Installing Output Shaft Elements.....	21
7.2- Correct Position of Output Shaft Elements.....	21
7.3- Coupling Connection.....	22
8- Maintenance & Inspection	23
9- Lubrication	24
9.1- Oil Types	24
9.2- Changing the Oil.....	25
9.3- Oil Quantities (lt).....	26
9.4- Mounting Positions	32
10- Troubleshooting Guide	33
11- Disposal.....	36
11.1- Disposal of Oil	36
11.2- Disposal of the seals.....	36
11.3- Disposal of Metal Parts.....	36



1- How To Use This Manual

Please pay attention to the following safety and warning instructions.



Electrical Hazard ; Can cause severe or fatal injuries.



Mechanical Hazard; Can cause severe or fatal injuries.



Likely to be Hazardous; Can cause minor or fatal injuries.



Damage Risk; Can damage gearbox or environment.



Important Information.



EC Machinery Directive:

Within terms of the EC machinery directive 2006/42/EC, the gearboxes are not considered as autonomous machines.

Operation is prohibited within the area of validity of the EC directive, until it has been determined that the machine, in which this product is installed, corresponds to the regulations within this directive.

The operating instructions contain important information to ensure;

- Trouble-free operation
- Fulfilment of any rights to claim under guarantee

The operating instruction must be kept close to the gearbox and must be available in case it is needed.

This operating instruction is written for D series gear units and is applicable only for D series. If any different type of gearbox is used please ask JS-Technik GmbH for the operating instructions of that type.

This instruction can be used only for standard type geared units of JS-Technik GmbH. For special application and modified gear units ask JS-Technik GmbH for validity.

This manual does not cover 94/9/EC compatible gearboxes. For 94/9/EC contact JS-technik GmbH.



2- Unit Designation

2.1- Detailed Unit Designation



M R 4 7 3 - 90S / 4 - L02

Brake
 L-220V With Fan
 P-24V With Fan
 S-220 V Without Fan
 Z-24 V Without Fan
 01-10 Nm 10-100 Nm
 02-25 Nm 20-200 Nm
 04-40 Nm 30-300 Nm
 05-50 Nm 40-400 Nm

Motor Size

For MV / NV Types

For MN / NN types

90S / 4

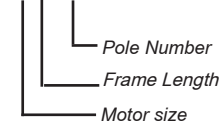

A06 :63 B5	A09 : 90 B5	A13 :132 B5	A25 : 250 B5
B06 :63 B14	B09 : 90 B14	B13 :132 B14	A28 : 280 B5
A07 :71 B5	A10 :100 B5	A16 :160 B5	A31 : 315 B5
B07 :71 B14	B10 :100 B14	A18 :180 B5	
A08 :80 B5	A11 :112 B5	A20 :200 B5	
B08 :80 B14	B11 :112 B14	A22 :225 B5	

Stage

2 Stages 5 Stages
 3 Stages 6 Stages
 4 Stages

Revision Number

Housing Size

1...9

Input Type

R :With Motor
N :IEC B5 / B14 Flanged without Motor
V : IEC B5 / B14 Flanged with Motor
T : Without Motor
RF : With Motor and Output Flange, Foot Mounted (M Type)
RB : With Motor, Agitator Neck at Output (N Type)
TF : Without Motor and Output Flange, Foot Mounted (M Type)
TB : Without Motor, Agitator Neck at Output (N Type)

Gearbox Type

M Series
 N Series

Operating Instructions

M/N Series

Type Designations



2.2- Nameplate, unit designation



Nameplate unit designation is a short abbreviation from the detailed designation

A sample name plate for M Series

JS-Technik GmbH www.js-technik.de		CE
Type : MR473-90 S / 4B		
Serial N.: 100658986		
Power: 1,1 kW	Ratio: 219	
Speed: 6,6 rpm.	M. Pos.: M1	
Oil: ISO VG 320 (Mineral)	Oil Qty : 4 lt.	

Abbreviations:

Serial N. : Serial Number

M.Pos. : Mounting Position

MR473
Type

90 L / 4
Motor Size

Serial Number: 100658986



Part Designations

3. Standard Type Gearbox Parts List
3.1- M...Type 3 Stages

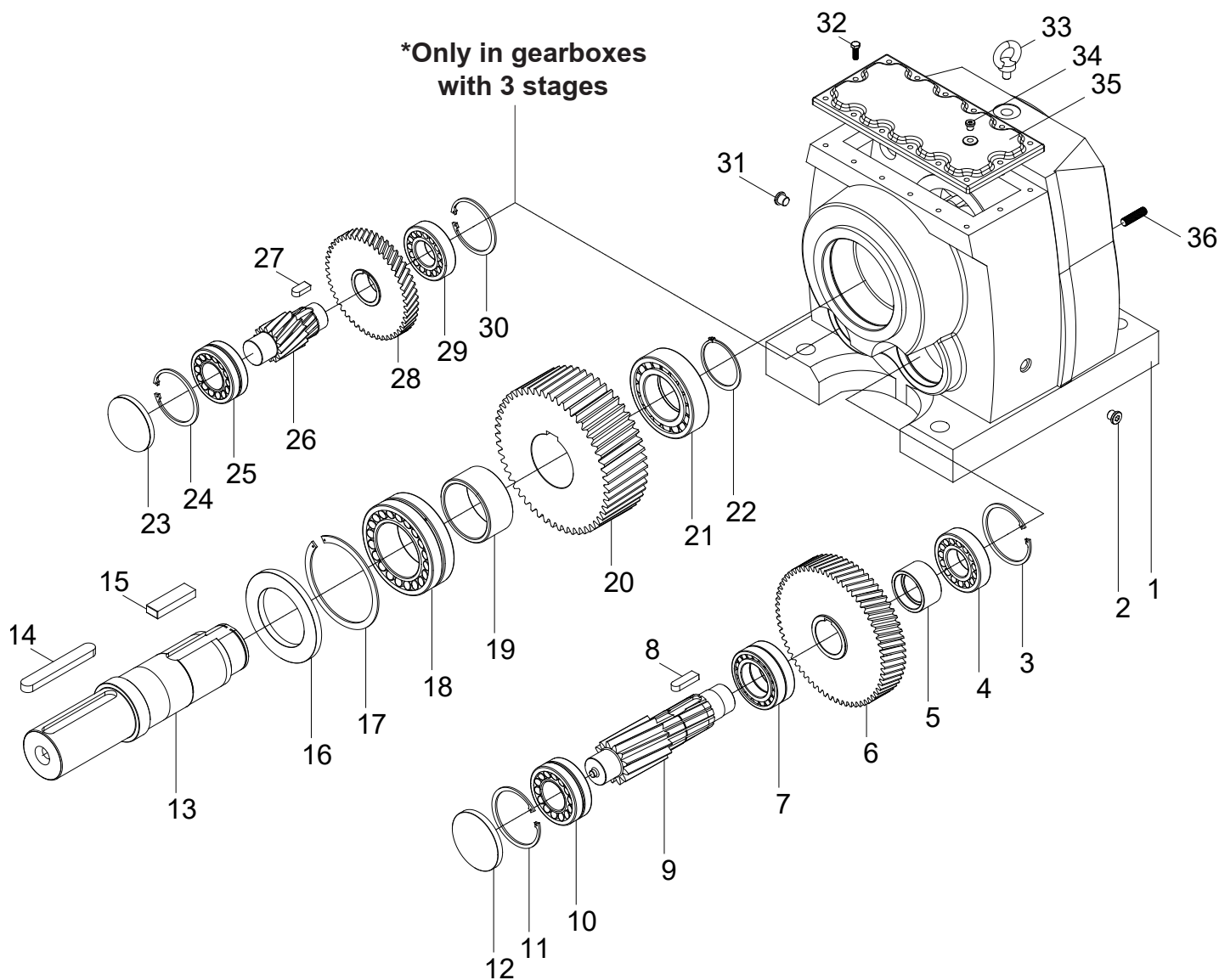

Standard M type 3 stages basic part diagram. Parts may differ for special applications.

Parts List

1- Housing	9- Gear	17- Circlips	25- Bearing	33- Eye Bolt
2- Oil plug	10- Bearing	18- Bearing	26- Gear	34- Oil plug
3- Circlips	11- Circlips	19- Spacer	27- Key	35- Top Side Cover
4- Bearing	12- Cover	20- Gear	28- Gear	36- Screw Pin
5- Spacer	13- Output shaft	21- Bearing	29- Bearing	
6- Gear	14- Key	22- Circlips	30- Circlip	
7- Bearing	15- Key	23- Cover	31- Oil plug	
8- Key	16- Seal	24- Circlips	32- Bolt	

Operating Instructions

M/N Series

Part Designations



3.2- N...Type 3 Stages

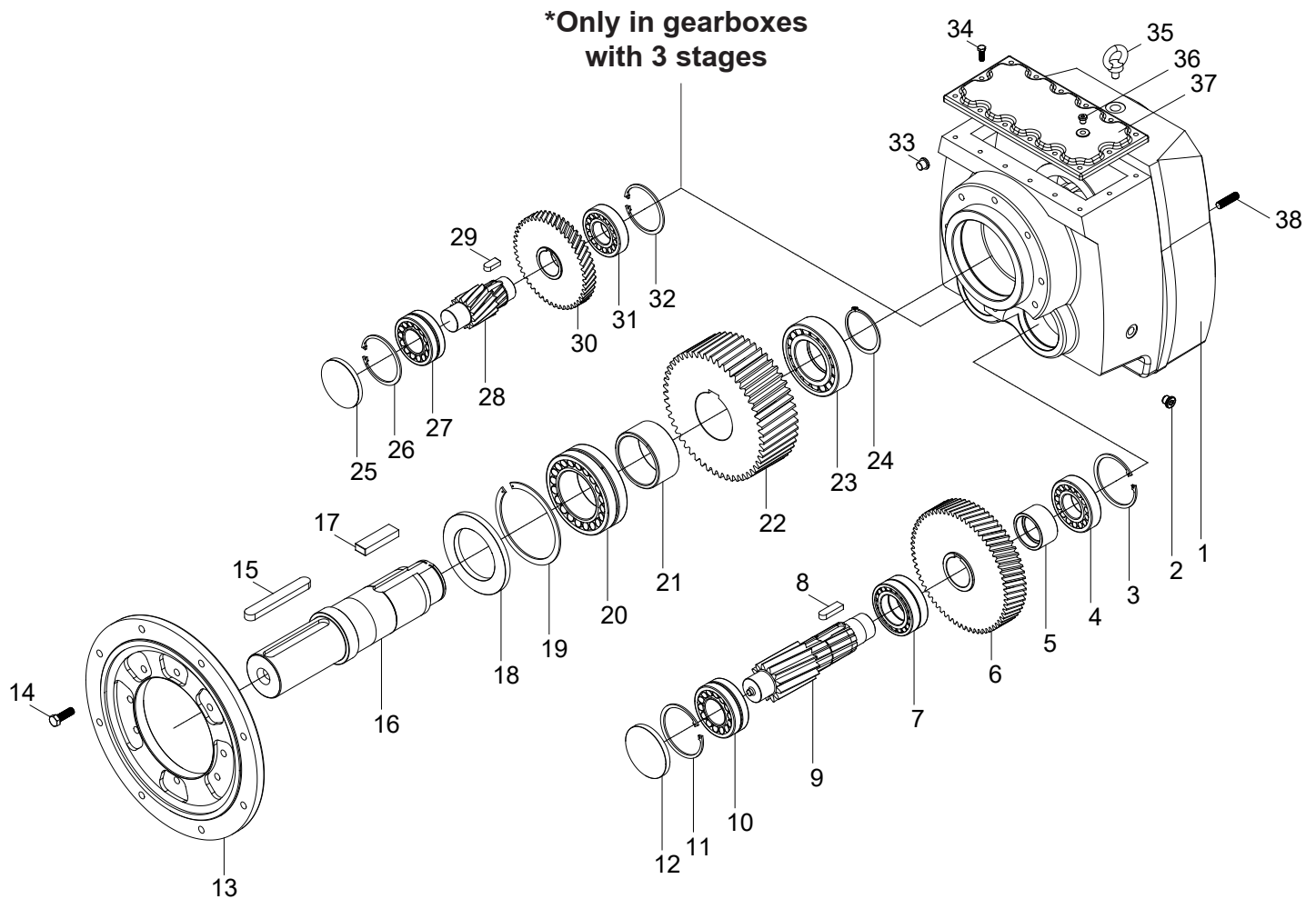

Standard N type 3 stages basic part diagram. Parts may differ for special applications.

Parts List

1- Housing	9- Gear	17- Key	25- Cover	33- Oil plug
2- Oil plug	10- Bearing	18- Seal	26- Circlips	34- Bolt
3- Circlips	11- Circlips	19- Circlips	27- Bearing	35- Eye bolt
4- Bearing	12- Cover	20- Bearing	28- Gear	36- Oil plug
5- Spacer	13- Output Flange	21- Spacer	29- Key	37- Top side cover
6- Gear	14- Bolt	22- Gear	30- Gear	38- Screw Pin
7- Bearing	15- Key	23- Bearing	31- Bearing	
8- Key	16- Output Shaft	24- Circlips	32- Circlips	

3.3- M, N... Additional Stage for 4 Stage Types

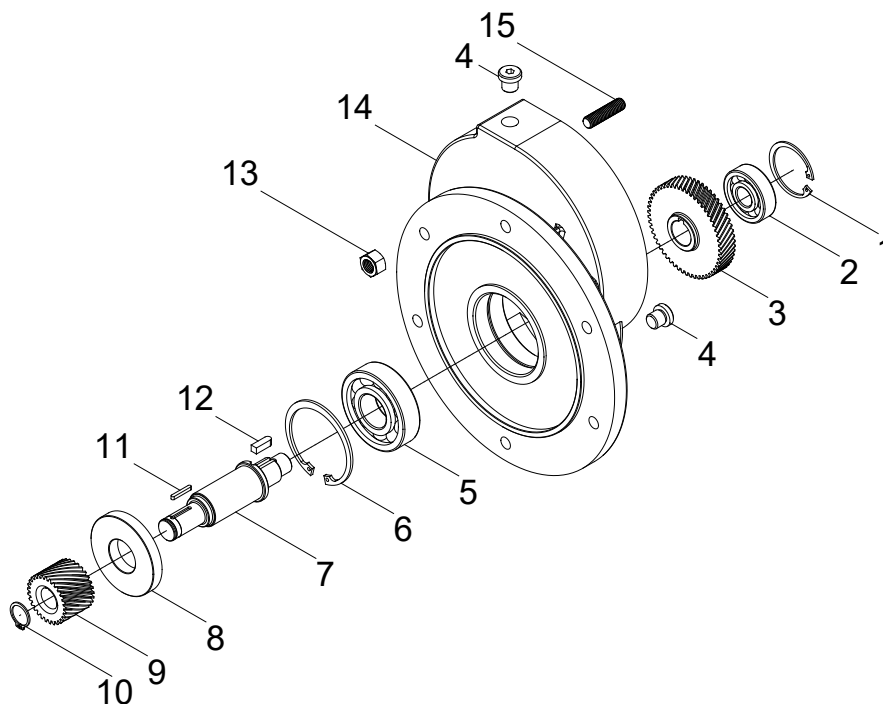

M, N additional stage for 4 stage types part diagram. (Standard)

Parts List

1- Circlips	9- Gear
2- Bearing	10- Circlips
3- Gear	11- Key
4- Oil plug	12- Key
5- Bearing	13- Bolt
6- Circlips	14- Additional Housing
7- Shaft	15- Screw Pin
8- Seal	

Operating Instructions

M/N Series

Part Designations



3.4- M, N...Motor Flange for Direct Coupled Types

Parts List

1- Shaft	6- Key
2- Circlips	7- Gear
3- Bearing	8- Circlips
4- Circlips	9- Nut
5- Flange	10- Key

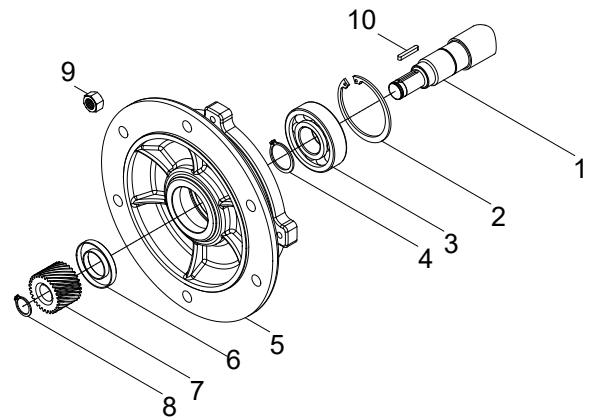

3.5- M, N...Types B5, B14 Motor Flange

Parts List

1- Shaft	6- Seal
2- Circlips	7- Gear
3- Bearing	8- Circlips
4- Circlips	9- Nut
5- B5 / B14 Flange	10- Key

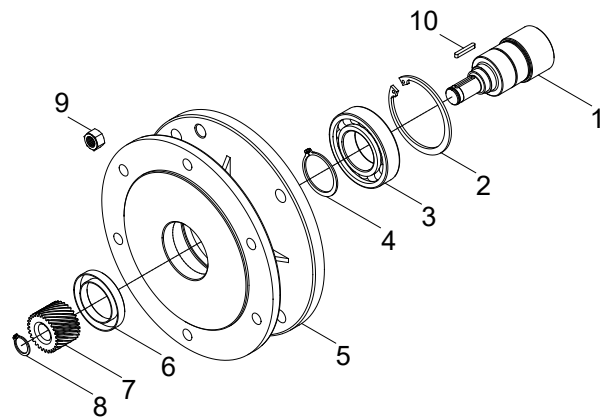

3.6- M, N Types...Input Bearing Housing with Solid Input Shaft

Parts List

1- Seal	7- Circlips
2- Nut	8- Gear
3- Flange	9- Circlips
4- Shaft	10- Key
5- Bearing	11- Key
6- Bearing	

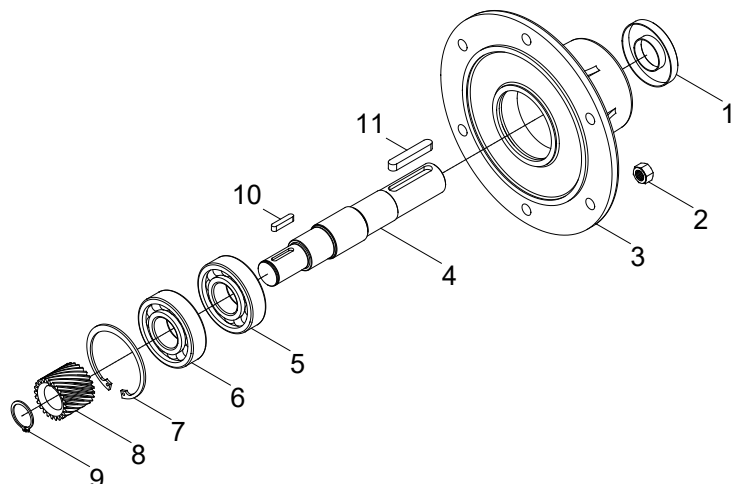



4- Safety

4.1- Intended Use

These gear units are designed for industrial use. Please refer to our catalogue or our web page for the maximum permitted torques and speeds. The most important maximum permitted values are indicated on the nameplate of the product. The complete information can be found in our product catalogue. Using the product out of the product catalogue / nameplate's permitted ranges will cancel the warranty/manufacturer declaration and JS-Technik GmbH will not take any responsibility.

The gear units are intended for industrial machines and may only be used in accordance with the information provided in this manual the product catalogue and the nameplate of the gearbox. They comply with the applicable standards and regulations and meet the requirements of the directive 2006/42/EC. The gearbox must be started up, maintained, and operated according to this manual. The gearbox must be incorporated with 2006/42/EC confirming parts/machines.



Motor installation and/or operation is only permitted if the permissible catalogue values or name plate data are not exceeded. For frequency inverter operation, the speed range can be entered on the type plate. The information must be provided when the order is placed. Without notification, only a fixed speed is entered on the name plate; a subsequent speed change is not permitted. The three-phase motor and frequency inverter must comply with directive 2006/42/EC.



If the gearboxes are to be operated with a speed controller, this must be stated when the order is requested or placed. The permissible maximum and minimum speed range is entered on the name plate. If no information is given when the order is placed, the gearbox will be delivered with a fixed speed and only this speed is permissible.



If the gearboxes are operated with a belt drive / coupling / chain drive etc., only the data on the name plate / catalogue values are permitted. Deviating speeds, higher motor outputs, higher radial/axial loads etc. are not permitted.



The ambient temperature may be between +5 and +40°C, abrasive medium must be kept away from the seals and paint. In the event of deviating operating conditions, JS-Technik must be informed before placing the order.



4.2- Improper Use

Every usage which exceeds the limits stated above, the nameplate and catalogue of the product (especially higher torques and speeds) is not compliant with the regulations, and thus prohibited.

The operation of the gear unit is prohibited if:

- It was not mounted/installed according to regulations and this manual
- The gear unit is very dirty
- It is operated without lubricant
- The operating data exceeds the permissible catalogue data.



4.3- Safety Instructions

4.3.1- General Safety Instructions

4.3.1.1- Working on the gear unit



- Inappropriately executed work can lead to injury or damage.

Make sure that the gear unit is only installed, maintained and dismantled by trained technicians.



- Foreign bodies spinning through the air can cause grave injury.

Before putting the gear unit into operation, check that there are no foreign bodies or tools near the gear unit.

4.3.1.2- Operation



- Touching hot surfaces can lead to burns.

Do not touch the gear unit if its operation temperatures are too high or use suitable safety equipment like gloves.



- Rotating machinery can lead to injuries. There is danger of being trapped or pulled in!

Keep sufficient distance and mount a guard in front of the rotating machine parts. See relevant norms EN349+A1, EN13857.

4.3.1.3- Maintenance



- An unintentional start of the machine during maintenance work can lead to serious accidents.

Make sure no one can start the machine while you are working on it.



- Even a brief running of the machine during maintenance work can lead to accidents if the safety devices are not operating.

Make sure that all safety devices are mounted and active.

4.3.1.4- Lubricant



- Extended, intensive contact with oils can lead to skin irritations.

Avoid extended contact with oil, and clean oil off skin thoroughly.



- Hot oil can cause scalding.

When changing oil, protect yourself against contacting hot oil.

4.3.1.5- Ambient Conditions



- Standard gearboxes are allowed to work in ambient temperatures between +5 to +40°C unless differently specified on the nameplate. Using the gear unit out of this range can cause damage to the gear unit or environment. At ambient temperatures above +40°C, touching the gear unit surface can cause burns.



- If the gear unit will be used in outdoor applications the gear unit must be protected from rain snow and dust. Entering substances inside the gear unit from seals can damage the gear unit. Observe the safety instructions for outdoor use EN12100:2010.



4.4- Tightening Torques

All screws with a specified tightening torque should always be tightened and checked with a calibrated torque wrench. Use the following torques for the threaded bores over the gear unit housing. For connecting elements refer to the mechanical installation part.

Bolt Size	Class	Tightening Torque [Nm]
M8	8.8	23
M10	8.8	43
M12	8.8	77
M16	8.8	190
M20	8.8	370
M24	8.8	640

4.5- In case of Fire

The gear unit itself is not combustible. However, it usually contains a synthetic or mineral gear oil.

Please observe the following if the gear unit is situated in a burning environment.

4.5.1- Suitable extinguishing agents, Protective equipment

Always keep suitable extinguishing, protective equipment like carbon dioxide, powder, foam, fog easily accessible around the gear unit.



-High temperatures produce irritating steam.

Use a protective breathing apparatus.



4.5.2- Unsuitable extinguishing agents

Do not spray with water!



5- Things to Check Before the Gear Unit or Gear Motor is Installed



If gear motors are used, please also refer to the manual of the motor manufacturer.

Before installing the gear unit, please check that it has been delivered in full and check for any transportation damage. Points to take into consideration before you start to install the unit;

- You have received the correct operation manual for your product.
- The gearbox and all its parts are transported without damage.
- The gearbox is stored correctly according to the instructions in this manual.
- You have the latest product catalogue or you have access to our web page.

5.1- Transportation

Upon delivery of the gear unit, ensure that the delivery corresponds to the purchase contract and that there is no damage. If there is any transport damage, report it to the shipping company immediately, and inform us about the damage.



Use the upper foot connection holes for lifting up the gear unit by using eyebolts. The eyebolts should be capable to carry the weight of gearboxes. Do not hang additional loads on the gear box by lifting. Use suitable hoisting equipment that can hold the weight of the gear unit. Refer to the catalogue for various types weights. If the gearbox is delivered with steel carrying construction use the construction holes for lift-ing the gear unit. See drawing below for hoisting point



Do not stay beneath / under the lifting/hoisting equipment which may cause serious injuries by falling down objects, accidental movements, unexpected accidents.



Falling or hard placement can damage the gear unit.

Only use hoisting and securing equipment which is permitted for the size / weight of your gear unit. Ensure that the load is slowly and carefully handled and placed.

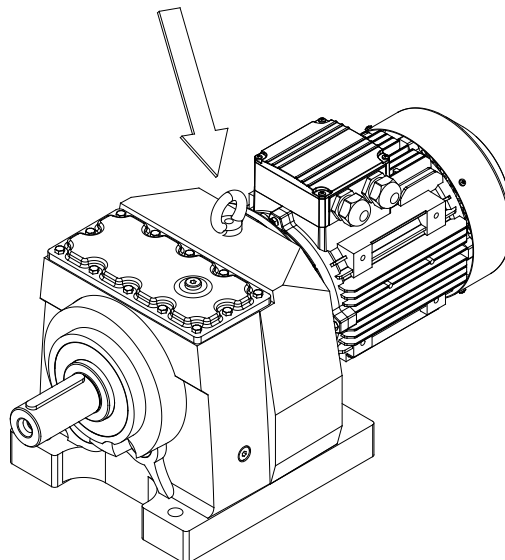



5.2- Storage

If the gear unit or gear motor will be stored up to 3 years refer to the following instructions:

With Packaging

-Use corrosion protection oil for the output shaft and connection surfaces like flange surface or foot assembling surface. Seal the unit in a plastic wrap and pack it in container. A moisture indicator should be placed around the container to observe the moisture. Relative atmospheric humidity should not exceed 50%. The container should be kept under roof which protects from snow and rain. Under these conditions, the gear unit can be stored for up to 3 years with regular checks. The ambient temperature should be between -5° to 60° Celsius.

Without Packaging

-Use protection oil for the output shaft and connection surfaces like flange surface or foot assembling surface. If the packaging is used and the gearbox is stored without packaging, the ambient temperature should be between 5° to 60° Celsius. The gearbox must be kept under enclosed roof with constant temperature and constant humidity not exceeding 50%. The storage should be free of dust and dirt and ventilated with filter. If the gearbox is stored without packaging it is recommended not to store it for more than 2 years and regular checks during this time are recommended.

If stored in open areas protect against insect damage.

6- Installing The Gear Unit

6.1- Before you start

- Observe the gear unit for damages of storage or transportation. If any damage please contact JS-Technik.
- Be sure that you have all the equipment necessary for installing like; Spanners, torque wrench, shims and distance rings, fixing devices for input and output elements, lubricant, bolt adhesive etc.



- This manual is not for 94/9/EC (ATEX) conforming gear units. For 94/9/EC conforming gear units refer to the ATEX range manual. ATEX conforming gear units have name plates indicating the zone and the temperature class and are different from standard type geared units. Therefore Standard units can not be installed on Potentially explosive atmospheres.



6.2- Check Shaft Dimensions and Tolerances

Type	Output Shaft Diameter	Output Shaft Tolerance (DIN748) Up to 50mm k6 Over 50mm m6	Flange Centering Shoulder Diameter (for N Series)	Centering Shoulder Tolerance (g6) (for N Series)
M/N...002/003..	20	+0.02 0	95	-0.01 -0.03
M/N...102/103...	25	+0.02 0	110	-0.01 -0.03
M/N...172/173...	25	+0.02 0	110	-0.01 -0.03
M/N...202/203...	30	+0.02 0	130	-0.01 -0.04
M/N...272/273...	35	+0.02 0	130	-0.01 -0.04
M/N...282/283...	35	+0.02 0	180	-0.01 -0.04
M/N...372/373...	40	+0.02 0	180	-0.01 -0.04
M/N...472/473...	50	+0.02 0	230	-0.02 -0.04
M/N...572/573...	60	+0.03 +0.01	250	-0.02 -0.04
M/N...672/673...	70	+0.03 +0.01	300	-0.02 -0.05
M/N...772/773...	90	+0.04 +0.02	350	-0.02 -0.06
M/N...872/873...	110	+0.04 +0.02	450	-0.02 -0.06
M/N...972/973...	120	+0.04 +0.02	550	-0.02 -0.06

6.3- Check the ambient temperature

The ambient temperature must be between +5 °C to +40 °C for standard type gear units. If different contact SEVA-tec GmbH for special solutions.

6.4- Check the voltage supply

The standard gear motors are supplied with 230/400V 50/60 Hz up to 3 kW including 3 kW and 400/690 V 50/60 Hz over 3 kW and is indicated on the motors name plate unless it is differently ordered. If only the gear unit is supplied from SEVA-tec GmbH please observe the name plate of the electric motor and the instructions of the supplier. Check the basic electric con-nection diagrams below. Use experienced electric technician.

Using wrong connection or voltage can damage the electric motor or environment.

The following wiring diagram is for standard 230/400 V 50 Hz AC electric motors. For different voltages please contact SEVA-tec GmbH. For gear units supplied without motor, refer to the motor manufacturers user manual.





The electrical installation and commissioning may only be carried out by qualified personnel. The gear unit and the motor must both be grounded separately.

6.4.1 Standard Circuit Diagrams for Electric Motors

Pole Number	Nominal Powers at 400V, 50Hz	
	230V (D) / 400 V (Y)	400V (D)
2 or 4	≤ 3 kW	≥ 4 kW
6	≤ 2,2 kW	≥ 3 kW
8	≤ 1,5 kW	≥ 2,2 kW
Starting Principle	Direct	Direct or Y/D

Basic motor connection wiring diagram

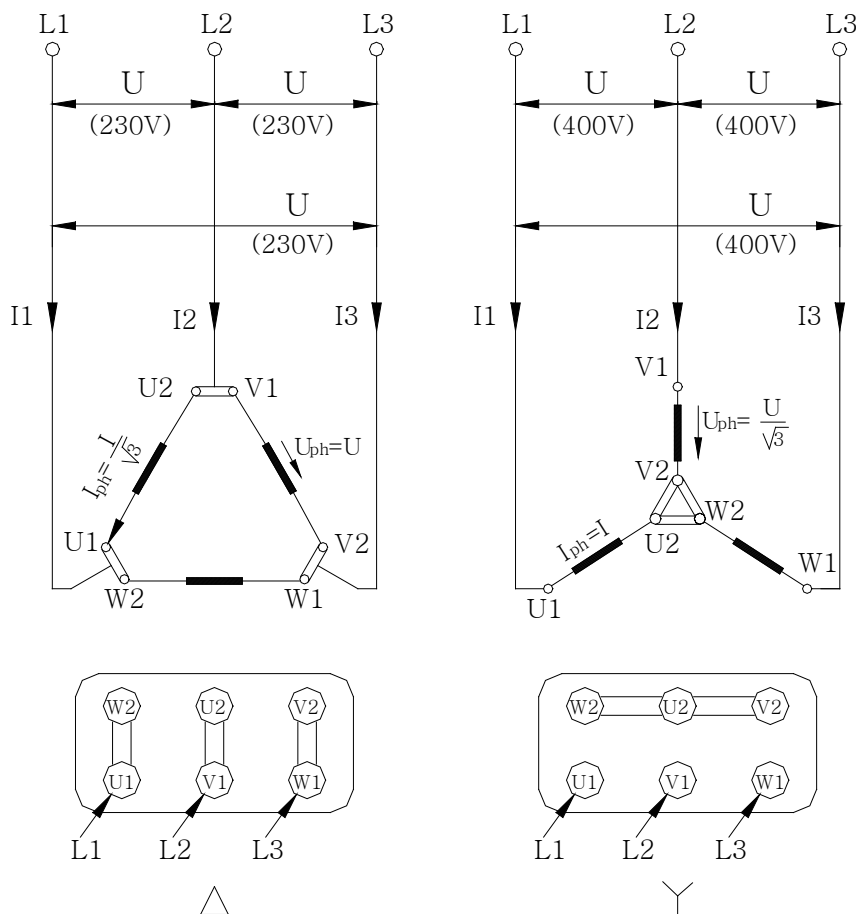



6.4.2 Standard Circuit Diagrams for Brake Motors

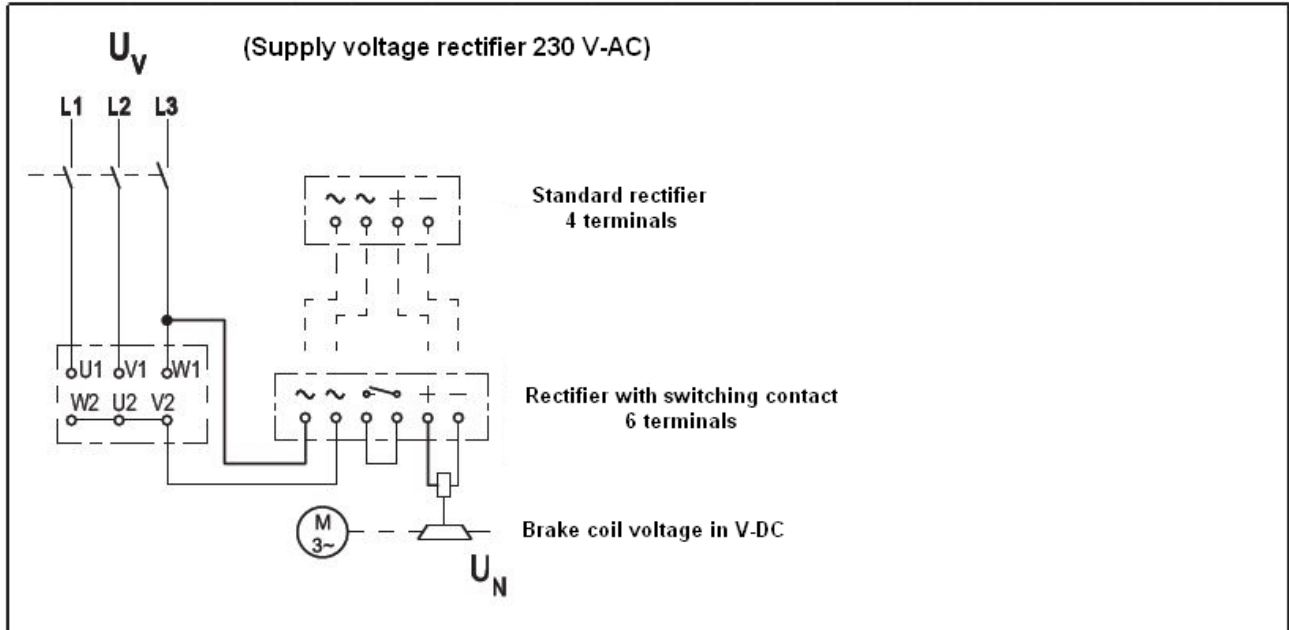

Supply: Phase-Starpoint

Bridge rectifier

$$U_N [\text{VDC}] = 0.9 \cdot U_V [\text{VAC}]$$

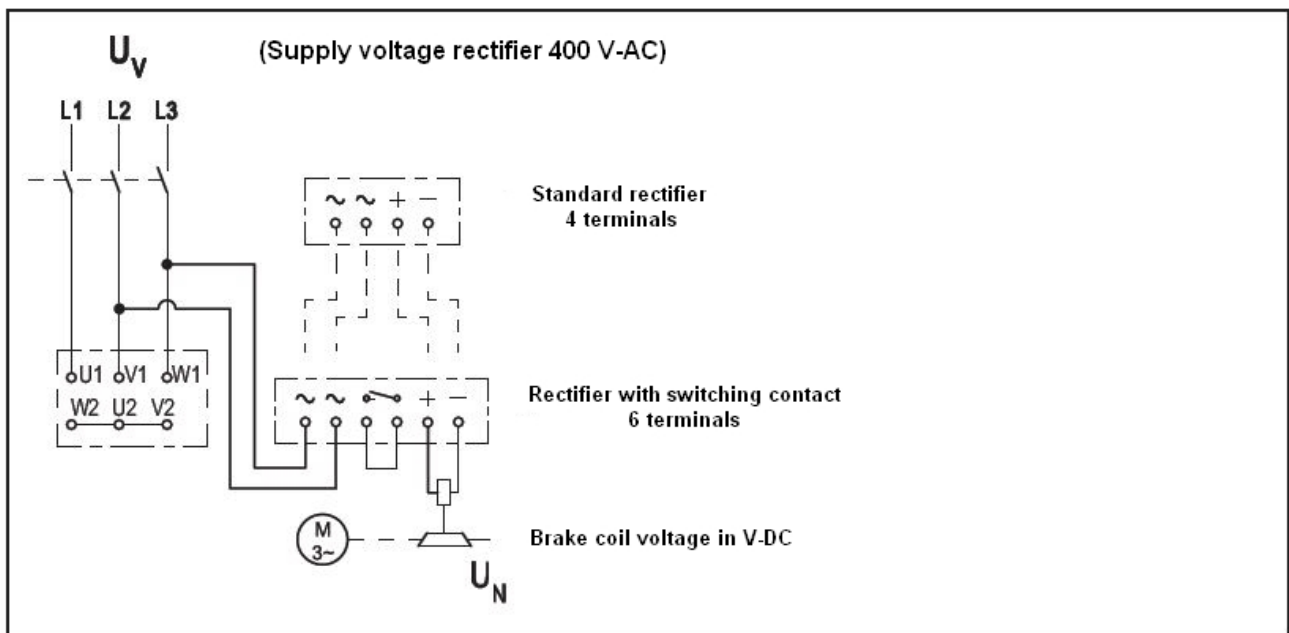

Supply: Phase-Phase

Half-wave rectifier

$$U_N [\text{VDC}] = 0.45 \cdot U_V [\text{VAC}]$$



6.5- Check the mounting position

The mounting position must be in accordance with the mounting position mentioned on the name plate. If different please contact JS-Technik GmbH for possibilities of using in a different mounting position. Refer to the mounting positions and oil quantities on this manual and adjust the oil level accordingly with the recommended oil types given on this manual.

STOP

Do not mix synthetic oils with mineral oils which can cause serious damage on the gear unit.

6.6- How to use of breather plug;

Breather plugs are recommended by JS-Technik for heavy ambient conditions and long working hours. They will be delivered together with the gearbox and must replace the plug located at the highest gearbox position after gearbox disassembly and before start-up.

i

Not all possible screw plug threads are machined. If no mounting position is specified in the order, the delivery is made in the standard "M1" position. Only the threads for the desired mounting position are then machined.

6.7- Check the oil level

Please refer to the installation position table and make sure that the oil level is correct according to the installation position. If the oil level is below the correct filling level, please take a wire to check. The oil level may be max. 3mm below the correct filling level. Please make sure that you use the correct oil. The required oil fill quantity and oil viscosity can also be found on the name plate.

STOP

Do not mix synthetic oils with mineral which can cause serious damage on the gear unit.

6.8- Checking shaft ends and mounting faces

Before starting assembly, make sure that the fasteners are free of dirt and oil. The output shafts are coated with anti-corrosion oil. Remove it with a commercially available solvent. It is essential to avoid solvent coming into contact with the sealing ring lips and the housing paint.

6.9- Protection from corrosive environment

If the gear motor is to be used in a dirty and abrasive environment, make sure that the shaft seals are protected against abrasive agents as well as chemical products and chemical liquids. Please protect the gearboxes and shaft seals from additional overpressure, which can cause protective particles (solid and liquid) to enter the gearbox via the shaft seal and destroy the gearbox. If gear motors cannot be protected against overpressure and abrasive dirt particles, please contact JS-Technik.

STOP

Abrasive material, chemicals, water, positive or negative pressure exceeding 0,2 bar can affect or damage the sealing lip or output shaft. Inside entering substances from the seals can cause serious damage to the gear unit.



6.10- Checking Accessibility to Oil Plugs

The oil filler, breather and exhaust plugs must be freely accessible for subsequent service work.

7- Mechanical Installation

The gear unit can only be installed using the supplied connection points like foot and flange assembling points.



Installing the gear unit without the supplied connection points can cause serious injuries by loosening or breaking the gear unit. Even if the gear unit is correctly installed according to this manual, ensure that no one will be harmed by accidental breakdowns or loosening.

Please ensure that the gearbox mountings are stable to prevent vibration and that it can be mounted on a machined surface without distortion. When using chain drives, this is especially important because of the polygon effect. If load shocks, prolonged overloads or blockages are likely to occur, install appropriate protective elements such as hydraulic clutches, etc. Check the radial and axial loads that occur. These must not exceed the permissible values. Take the permissible values from the product catalogue.



If the output or input shaft is overloaded by radial or axial loads it can cause serious damage to the gear unit.

Secure the gear unit using 8.8 or higher quality bolts.



Protect all rotating parts from possible contact. Rotating machine parts can lead to serious injuries.



For different kind of basic installations refer to the following illustrations.



7.1- Installing Output Shaft Elements

Use the following illustration to assemble output shaft units

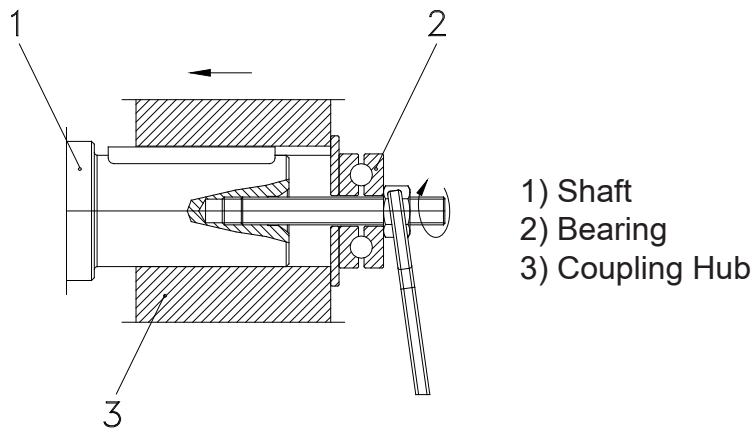

7.2- Correct position of output shaft elements

The output shaft unit (transmission elements) must be placed closely to the gear unit so that the radial load is as close as possible to the gear unit.

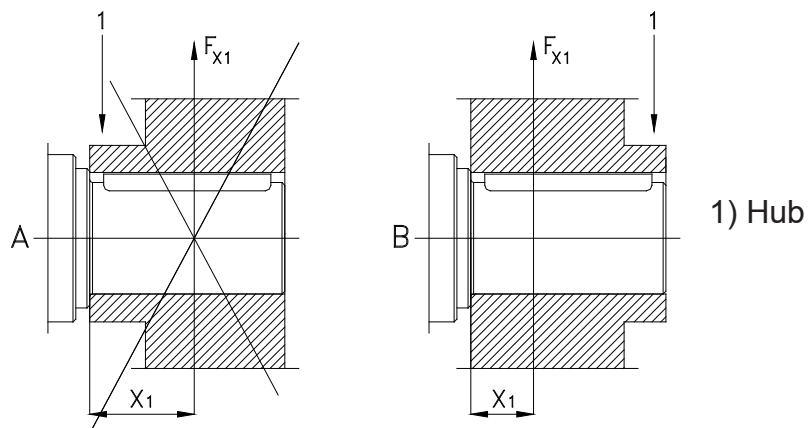



7.3- Coupling Connection

7.3.1- When installing the coupling, please ensure that there is an air gap between the two elements.

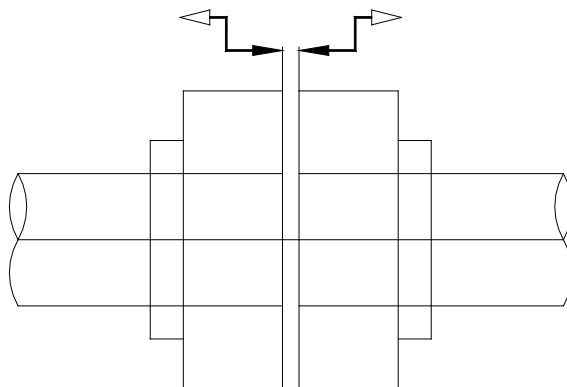

7.3.2- When installing the coupling, please observe the maximum permissible axial misalignment.

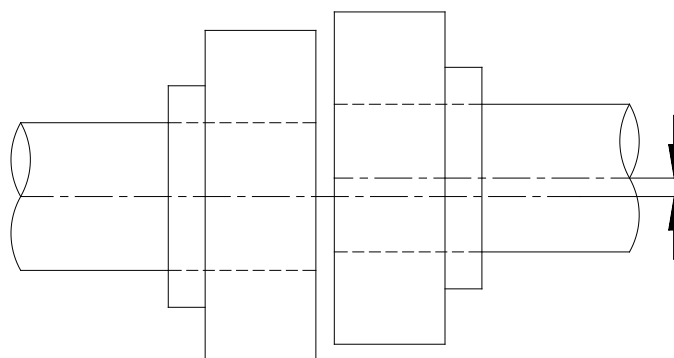

7.3.3- When installing the coupling, please observe the maximum permissible angular displacement.

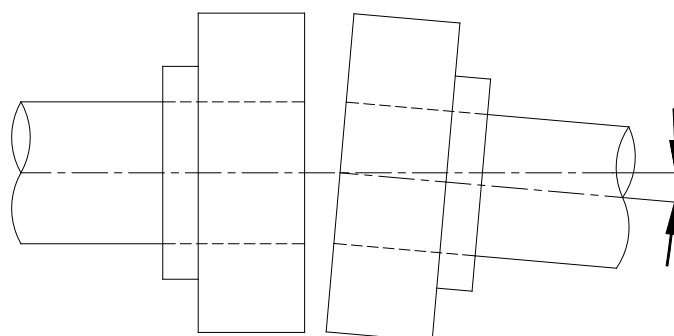



8- Maintenance and Inspections

Under normal ambient and operating conditions, the gear units should be inspected at the intervals listed in the table below.

Item to check / replace	Every 3.000 working hours or every 6 months	Every 4.000 working hours	Every 10.000 working hours or every 3 years	Every 25.000 working hours
Check for oil leakage	x			
Check for oil level	x			
Check oil leakage from seal	x			
Check Rubber buffer	x (Change if necessary)			
Check Bearings Noise		x (Change if necessary)		
Change Mineral Oil			x (See Below for details)	
Change Synthetic-PAO Oil				x (See Below for details)
Change Sealing				x
Change Bearing Grease				x
Change Bearings				x
Check for noise Changes				x

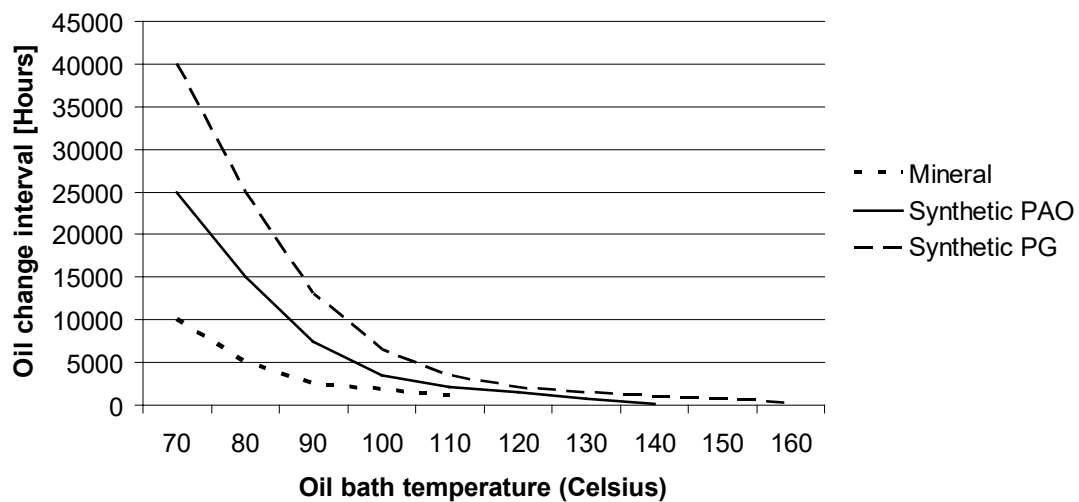

For normal ambient conditions 70 degrees Celsius oil bath temp. Should be taken as reference

* For M series Mineral oil is used unless it is differently ordered. For oil type and quantities refer to the following tables.

Operating Instructions







M/N Series

Lubrication



9- Lubrication

9.1- Oil Types

Lubricant	DIN 51517-3	Ambient Temperature [°C]		ISO VG	Aral	Beyond Petroleum	Castrol	Klüber Lubrication	Mobil	Shell	Total
		Dip Lubrication	Forced Lubrication								
Mineral Oil	CLP	0 ... +50	–	680	Degol BG 680	Energol GR-XP 680	Alpha SP 680	Klüberoil GEM 1-680 N	Mobilgear XMP 680	Omala 680	Carter EP 680
		-5 ... +45	–	460	Degol BG 460	Energol GR-XP 460	Alpha SP 460	Klüberoil GEM 1-460 N	Mobilgear XMP 460	Omala F460	Carter EP 460
		-10 ... +40	+15 ... +40	320	Degol BG 320	Energol GR-XP 320	Alpha SP 320	Klüberoil GEM 1-320 N	Mobilgear XMP 320	Omala F320	Carter EP 320
		-15 ... +30	+10 ... +30	220	Degol BG 220	Energol GR-XP 220	Alpha SP 220	Klüberoil GEM 1-220 N	Mobilgear XMP 220	Omala F220	Carter EP 220
		-20 ... +20	+5 ... +20	150	Degol BG 150	Energol GR-XP 150	Alpha SP 150	Klüberoil GEM 1-150 N	Mobilgear XMP 150	Omala 150	Carter EP 150
		-25 ... +10	+3 ... +10	100	Degol BG 100	Energol GR-XP 100	Alpha SP 100	Klüberoil GEM 1-100 N	–	Omala 100	Carter EP 100
Synthetic Oil	CLP PG	-10 ... +60	–	680	Degol GS 680	Energol SG-XP 680	–	Klübersynth GH 6 -680	Mobil Glygoyle 680	Tivela S 680	Carter SY 680
		-20 ... +50	–	460	Degol GS 460	Energol SG-XP 460	Aphasyn PG 460	Klübersynth GH 6 -460	Mobil Glygoyle 460	Tivela S 460	Carter SY 460
		-25 ... +40	+5 ... +40	320	Degol GS 320	Energol SG-XP 320	Aphasyn PG 320	Klübersynth GH 6 -320	Mobil Glygoyle 320	Tivela S 320	Carter SY 320
		-30 ... +30	0 ... +30	220	Degol GS 220	Energol SG-XP 220	Aphasyn PG 220	Klübersynth GH 6 -220	–	Tivela S 220	Carter SY 220
		-35 ... +20	-5 ... +20	150	Degol GS 150	Energol SG-XP 150	Aphasyn PG 150	Klübersynth GH 6 -150	–	Tivela S 150	Carter SY 150
		-40 ... +10	-8 ... +10	100	–	–	–	Klübersynth GH 6 -100	–	–	–
	CLP HC	-10 ... +60	–	680	–	–	–	Klübersynth GEM 4-680 N	Mobilgear SHC XMP 680	–	Carter SH 680
		-20 ... +50	–	460	Degol PAS 460	Energol EP-XF 460	Alphasyn T 460	Klübersynth GEM 4-460 N	Mobilgear SHC XMP 460	Omala HD 460	Carter SH 460
		-25 ... +40	+5 ... +40	320	Degol PAS 320	Energol EP-XF 320	Alphasyn T 320	Klübersynth GEM 4-320 N	Mobilgear SHC XMP 320	Omala HD 320	Carter SH 320
		-30 ... +30	0 ... +30	220	Degol PAS 220	Energol EP-XF 220	Alphasyn T 220	Klübersynth GEM 4-220 N	Mobilgear SHC XMP 220	Omala HD 220	Carter SH 220
		-35 ... +20	-5 ... +20	150	Degol PAS 150	Energol EP-XF 150	Alphasyn T 150	Klübersynth GEM 4-150 N	Mobilgear SHC XMP 150	Omala HD 150	Carter SH 150
		-40 ... +10	-8 ... +10	100	–	–	–	Klübersynth GEM 4-100 N	–	–	–
Food Grade Oil	CLP NSF H1	-15 ... +25	+5 ... +25	220	–	–	Optileb GT 220	Klüberoil 4 UH1-220 N	Mobil SHC Cibus 220	Cassida Fluid GL-220	Nevastane SL 220
Biode- gradable Oil	CLP E	-25 ... +40	+5 ... +40	320	–	–	Tribol BioTop 1418-320	Klübersynth GEM 2-320	–	–	Carter Bio 320
Mineral Grease [-20 +120 Working Temperature °C]					Aralub HL3	Energol LS 3	Spheerol AP3	Centplex 2 EP	Mobilux EP 3	Alvania RL3	Multis Complex EP 2
Synthetic Grease [-30 +100 Working Temperature °C]					–	Energol SY 2202	–	Petamo GHY 133 N	Mobiltemp SHC 100	Cassida RLS 2	Multis Complex SHD 220



9.2- Changing the oil

In the operating instructions you can find the required oil filling quantity.



-Do not mix synthetic oils with mineral oils which will cause serious damage to the gear unit. The oil change must be done by using the filling, draining, and level plugs according to the mounting position illustrated in section 9.4.



-Extended, intensive contact with oils can lead to skin irritations.
Avoid extended contact with oil, and clean oil off skin thoroughly.



-Hot oil can cause scalding.
When changing oil, protect yourself against contacting hot oil.

Operating Instructions

M/N Series

Lubrication



9.3- Oil Quantities (l)

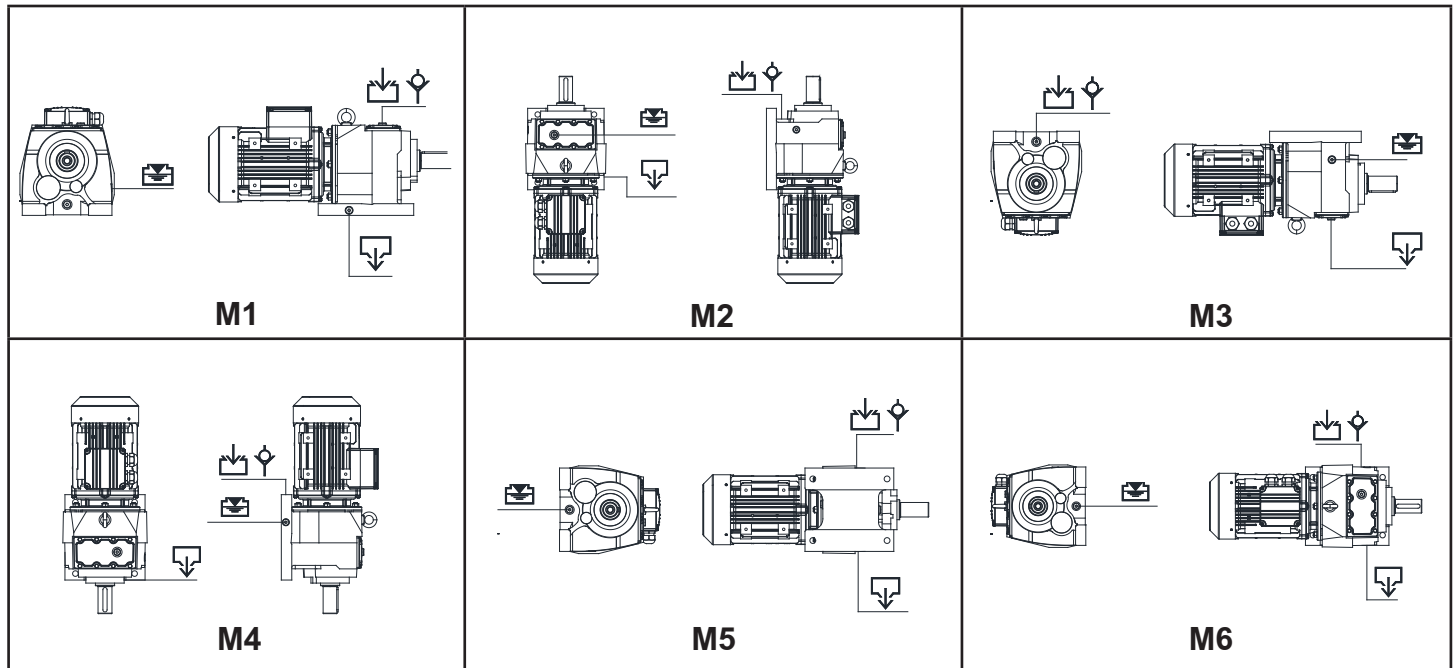

Type	M Series 2-3 Stages Oil Quantities					
	M1	M2	M3	M4	M5	M6
M002 / 003	0.4 / 0.35	0.6 / 0.55	0.5 / 0.5	0.6 / 0.55	0.5 / 0.4	0.5 / 0.4
M102 / 103	0.65 / 0.6	0.95 / 0.8	0.7 / 0.7	0.95 / 0.8	0.7 / 0.7	0.7 / 0.7
M172 / 173	0.7 / 0.65	0.95 / 0.9	0.8 / 0.8	0.95 / 0.9	0.8 / 0.7	0.8 / 0.7
M202 / 203	1.2 / 1.1	2.1 / 2	2 / 1.9	2.1 / 2	1.4 / 1.3	1.4 / 1.3
M272 / 273	1.1 / 1	2 / 1.7	1.9 / 1.5	2 / 1.7	1.3 / 1.2	1.3 / 1.2
M282 / 283	1.7 / 1.6	3 / 2.85	2.8 / 2.5	3 / 2.85	2.6 / 2.4	2.6 / 2.4
M372 / 373	2 / 1.9	3.4 / 3.3	3.1 / 3	3.4 / 3.3	2.8 / 2.6	2.8 / 2.6
M472 / 473	4.5 / 4	8 / 7.6	7.5 / 7	8 / 7.6	5.5 / 5	5.5 / 5
M572 / 573	7 / 6	12.8 / 11.7	11.5 / 10.5	12.8 / 11.7	8 / 7.5	8 / 7.5
M672 / 673	10 / 8.5	22.5 / 20	20 / 18	22.5 / 20	11 / 11	11 / 11
M772 / 773	20 / 18	35 / 32	30 / 28	35 / 32	22 / 20	22 / 20
M872 / 873	28 / 20	53 / 45	45 / 39	53 / 45	30 / 28	30 / 28
M972 / 973	53 / 50	90 / 87	82 / 80	90 / 87	70 / 65	70 / 65

Symbols :  :Oil filling  :Drain plug  :Oil level  :Vent Plug

Operating Instructions

M/N Series

Lubrication



Oil Levels, Plugs, and Quantities

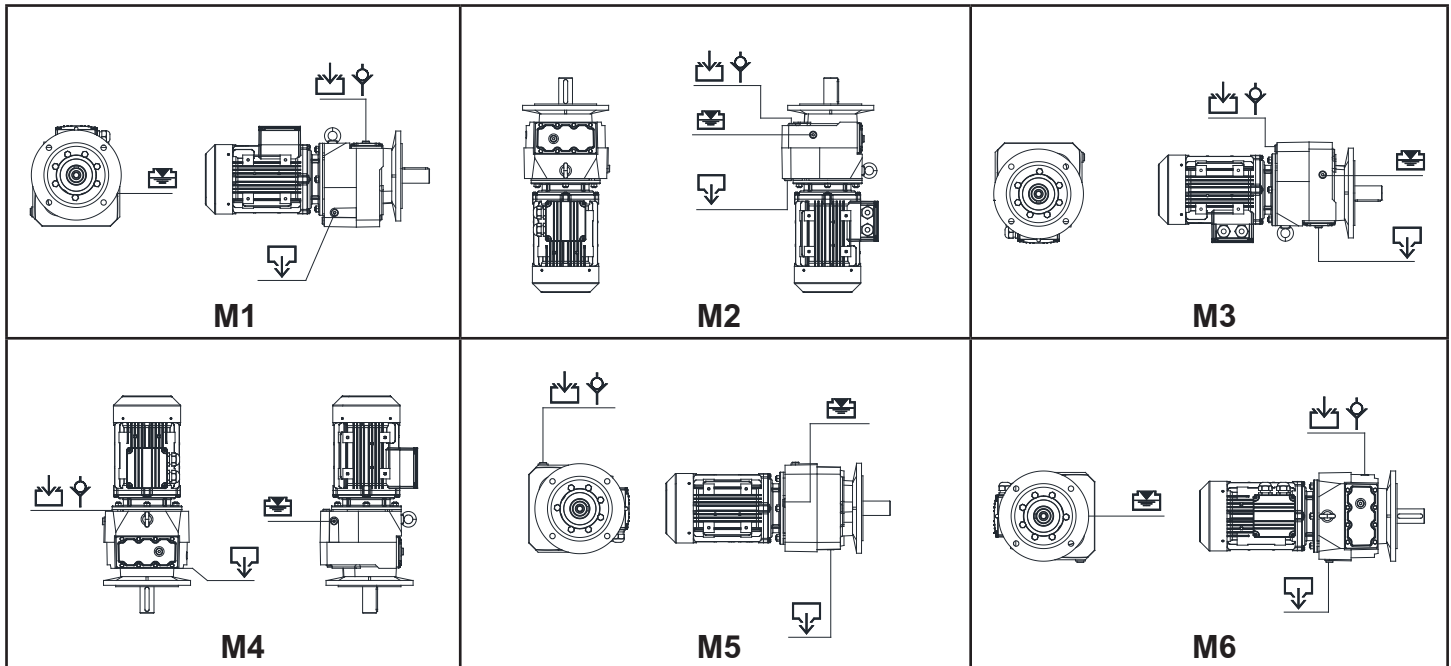

Type	N Series 2-3 Stages Oil Quantities					
	M1	M2	M3	M4	M5	M6
N002 / 003	0.4 / 0.35	0.6 / 0.55	0.5 / 0.5	0.6 / 0.55	0.5 / 0.4	0.5 / 0.4
N102 / 103	0.65 / 0.6	0.95 / 0.8	0.7 / 0.7	0.95 / 0.8	0.7 / 0.7	0.7 / 0.7
N172 / 173	0.7 / 0.65	0.95 / 0.9	0.8 / 0.8	0.95 / 0.9	0.8 / 0.7	0.8 / 0.7
N202 / 203	1.2 / 1.1	2.1 / 2	2 / 1.9	2.1 / 2	1.4 / 1.3	1.4 / 1.3
N272 / 273	1.1 / 1	2 / 1.7	1.9 / 1.5	2 / 1.7	1.3 / 1.2	1.3 / 1.2
N282 / 283	1.7 / 1.6	3 / 2.85	2.8 / 2.5	3 / 2.85	2.6 / 2.4	2.6 / 2.4
N372 / 373	2 / 1.9	3.4 / 3.3	3.1 / 3	3.4 / 3.3	2.8 / 2.6	2.8 / 2.6
N472 / 473	4.5 / 4	8 / 7.6	7.5 / 7	8 / 7.6	5.5 / 5	5.5 / 5
N572 / 573	7 / 6	12.8 / 11.7	11.5 / 10.5	12.8 / 11.7	8 / 7.5	8 / 7.5
N672 / 673	10 / 8.5	22.5 / 20	20 / 18	22.5 / 20	11 / 11	11 / 11
N772 / 773	20 / 18	35 / 32	30 / 28	35 / 32	22 / 20	22 / 20
N872 / 873	28 / 20	53 / 45	45 / 39	53 / 45	30 / 28	30 / 28
N972 / 973	53 / 50	90 / 87	82 / 80	90 / 87	70 / 65	70 / 65

Symbols :  :Oil filling  :Drain plug  :Oil level  :Vent Plug

Operating Instructions M/N Series

Lubrication

Oil Levels, Plugs, and Quantities

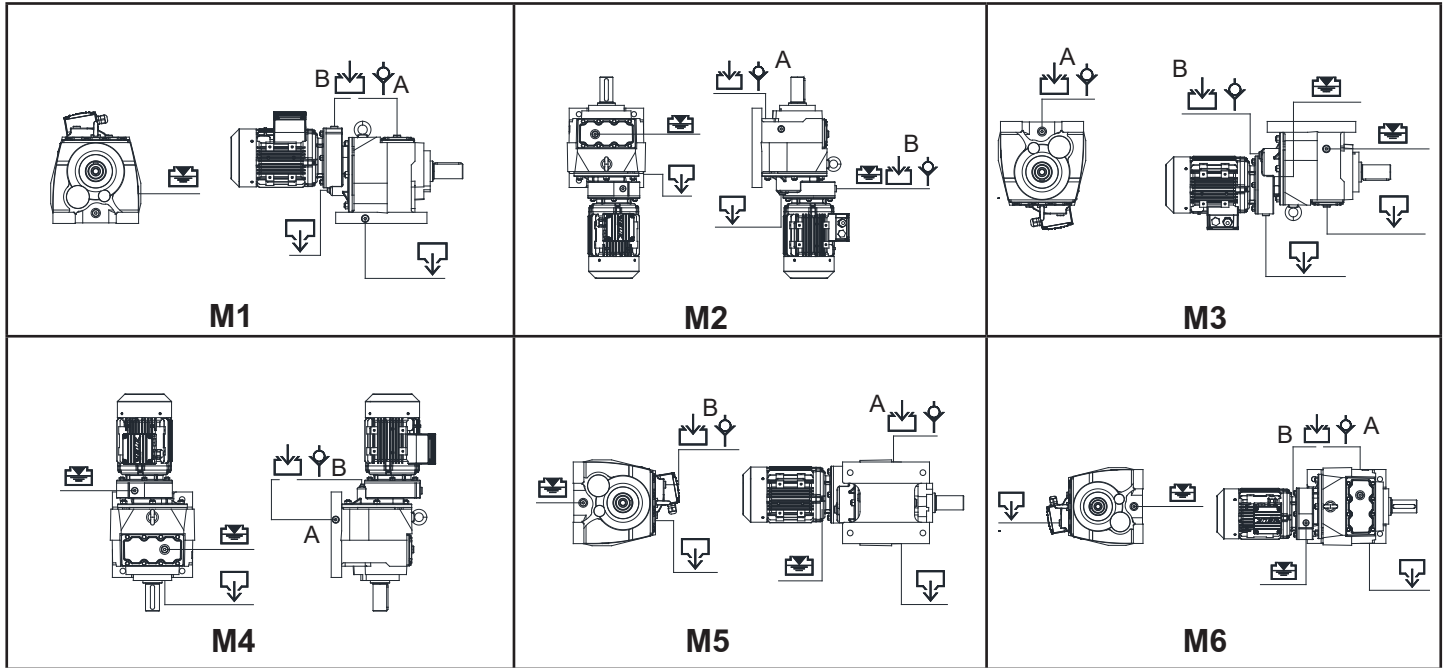

Type	M Series 4 Stages Oil Quantities					
	M1 A / B	M2 A / B	M3 A / B	M4 A / B	M5 A / B	M6 A / B
M284	1.6 / 0.25	2.85 / 0.25	2.5 / 0.25	2.85 / 0.25	2.4 / 0.25	2.4 / 0.25
M374	1.9 / 0.25	3.3 / 0.25	3 / 0.25	3.3 / 0.25	2.6 / 0.25	2.6 / 0.25
M474	4 / 0.4	7.6 / 0.4	7 / 0.4	7.6 / 0.4	5 / 0.4	5 / 0.4
M574	6 / 0.50	11.7 / 0.50	10.5 / 0.50	11.7 / 0.50	7.5 / 0.50	7.5 / 0.50
M674	8.5 / 0.90	20 / 0.90	18 / 0.90	20 / 0.90	11 / 0.90	10.5 / 0.90
M774	18 / 1	32 / 1	28 / 1	32 / 1	20 / 1	20 / 1
M874	20 / 2.15	45 / 2.15	39 / 2.15	45 / 2.15	28 / 2.15	28 / 2.15
M974	50 / 7	87 / 7	80 / 7	87 / 7	65 / 7	65 / 7

Symbols :  :Oil filling  :Drain plug  :Oil level  :Vent Plug

Operating Instructions

M/N Series

Lubrication



Oil Levels, Plugs, and Quantities

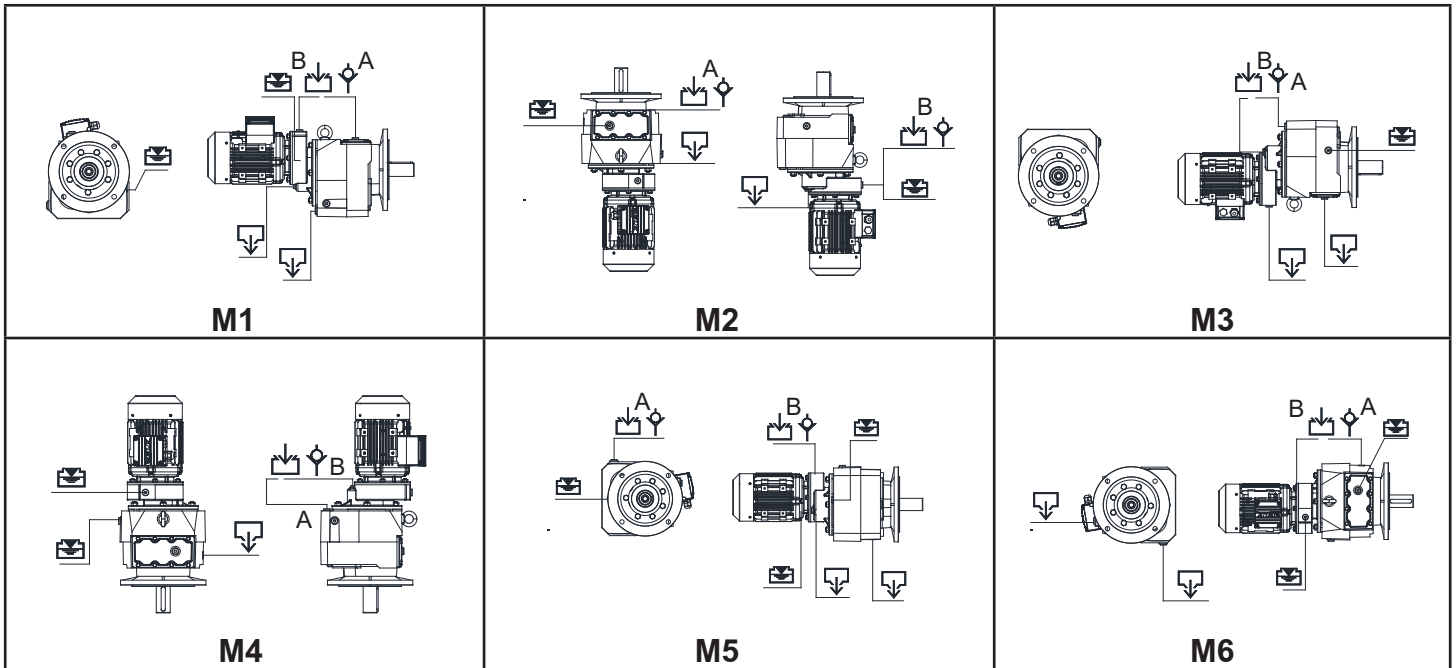

Type	N Series 4 Stages Oil Quantities					
	M1 A / B	M2 A / B	M3 A / B	M4 A / B	M5 A / B	M6 A / B
N284	1.6 / 0.25	2.85 / 0.25	2.5 / 0.25	2.85 / 0.25	2.4 / 0.25	2.4 / 0.25
N374	1.9 / 0.25	3.3 / 0.25	3 / 0.25	3.3 / 0.25	2.6 / 0.25	2.6 / 0.25
N474	4 / 0.4	7.6 / 0.4	7 / 0.4	7.6 / 0.4	5 / 0.4	5 / 0.4
N574	6 / 0.50	11.7 / 0.50	10.5 / 0.50	11.7 / 0.50	7.5 / 0.50	7.5 / 0.50
N674	8.5 / 0.90	20 / 0.90	18 / 0.90	20 / 0.90	11 / 0.90	10.5 / 0.90
N774	18 / 1	32 / 1	28 / 1	32 / 1	20 / 1	20 / 1
N874	20 / 2.15	45 / 2.15	39 / 2.15	45 / 2.15	28 / 2.15	28 / 2.15
N974	50 / 7	87 / 7	80 / 7	87 / 7	65 / 7	65 / 7

Symbols :  :Oil filling  :Drain plug  :Oil level  :Vent Plug

Operating Instructions M/N Series Lubrication



Oil Levels, Plugs, and Quantities

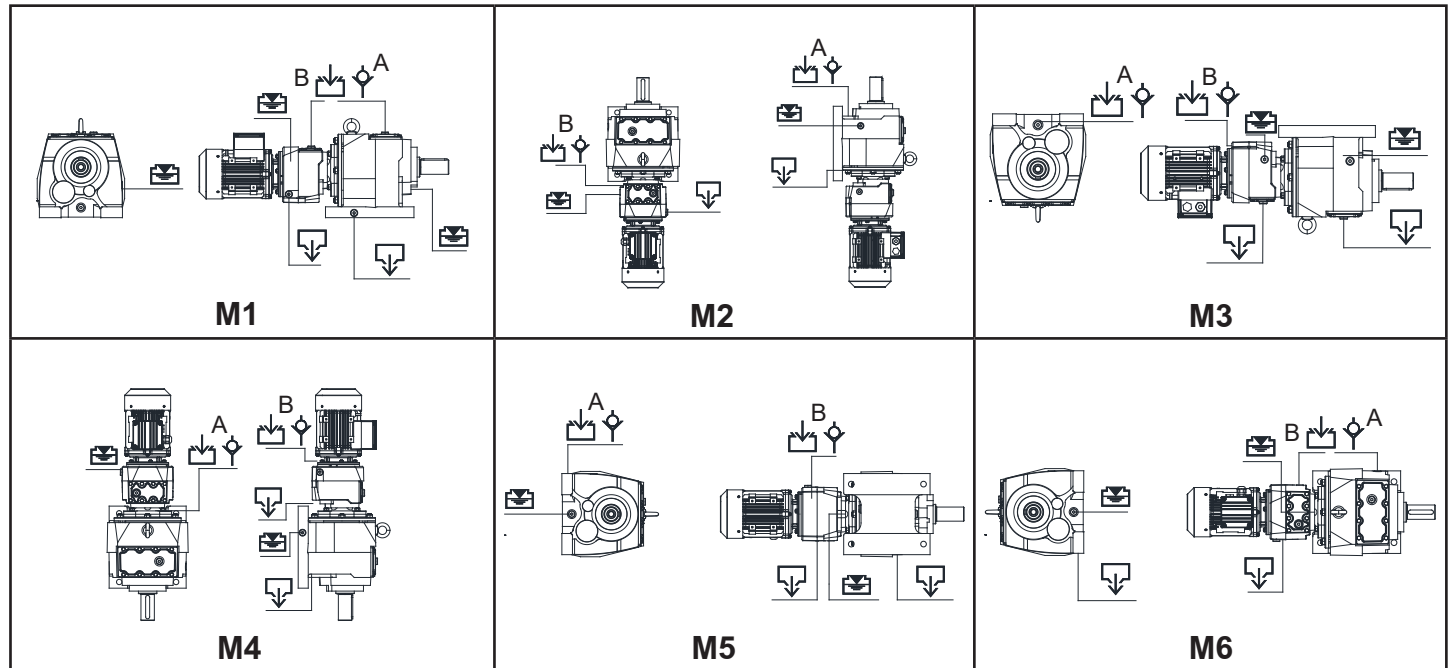

Type	M Series 5-6 Stages Oil Quantities					
	M1 A/B	M2 A/B	M3 A/B	M4 A/B	M5 A/B	M6 A/B
M275	1 / 0.4	1.7 / 0.6	1.5 / 0.5	1.7 / 0.6	1.2 / 0.5	1.2 / 0.5
M285	1.6 / 0.7	2.85 / 0.95	2.5 / 0.7	2.85 / 0.95	2.4 / 0.7	2.4 / 0.7
M375	1.9 / 0.7	3.3 / 0.95	3 / 0.7	3.3 / 0.95	2.6 / 0.7	2.6 / 0.7
M475	4 / 1.2	7.6 / 2.1	7.01 / 2.1	7.6 / 2.1	5 / 1.4	5 / 1.4
M575	6 / 1.2	11.7 / 2.1	10.5 / 2	11.7 / 2.1	7.5 / 1.4	7.5 / 1.4
M675	8.5 / 2	20 / 3.4	18 / 3.1	20 / 3.4	11 / 2.8	10.5 / 2.8
M775	18 / 2	32 / 3.4	28 / 3.1	32 / 3.4	20 / 2.8	20 / 2.8
M875	20 / 2	45 / 3.4	39 / 3.1	45 / 3.4	28 / 2.8	28 / 2.8
M975	50 / 4.5	87 / 8	80 / 7.5	87 / 8	65 / 5.5	65 / 5.5
M276	1 / 0.4	1.7 / 0.55	1.5 / 0.5	1.7 / 0.55	1.2 / 0.4	1.2 / 0.4
M286	1.6 / 0.6	2.85 / 0.8	2.5 / 0.7	2.85 / 0.8	2.4 / 0.7	2.4 / 0.65
M676	1.9 / 0.6	3.3 / 0.8	3 / 0.7	3.3 / 0.8	2.6 / 0.7	2.6 / 0.65
M476	4 / 1.1	7.6 / 2	7 / 1.9	7.6 / 2	5 / 1.3	5 / 1.3
M576	6 / 1.1	11.7 / 2	10.5 / 1.9	11.7 / 2	7.5 / 1.3	7.5 / 1.3
M676	8.5 / 1.9	20 / 3.3	18 / 3	20 / 3.3	11 / 2.6	10.5 / 2.6
M776	18 / 1.9	32 / 3.3	28 / 3	32 / 3.3	20 / 2.6	20 / 2.6
M876	20 / 1.9	45 / 3.3	39 / 3	45 / 3.3	28 / 2.6	28 / 2.6
M976	50 / 4	87 / 7.6	80 / 7	87 / 7.6	65 / 5	65 / 5

Symbols : :Oil filling :Drain plug :Oil level :Vent Plug

Operating Instructions

M/N Series

Lubrication



Oil Levels, Plugs, and Quantities

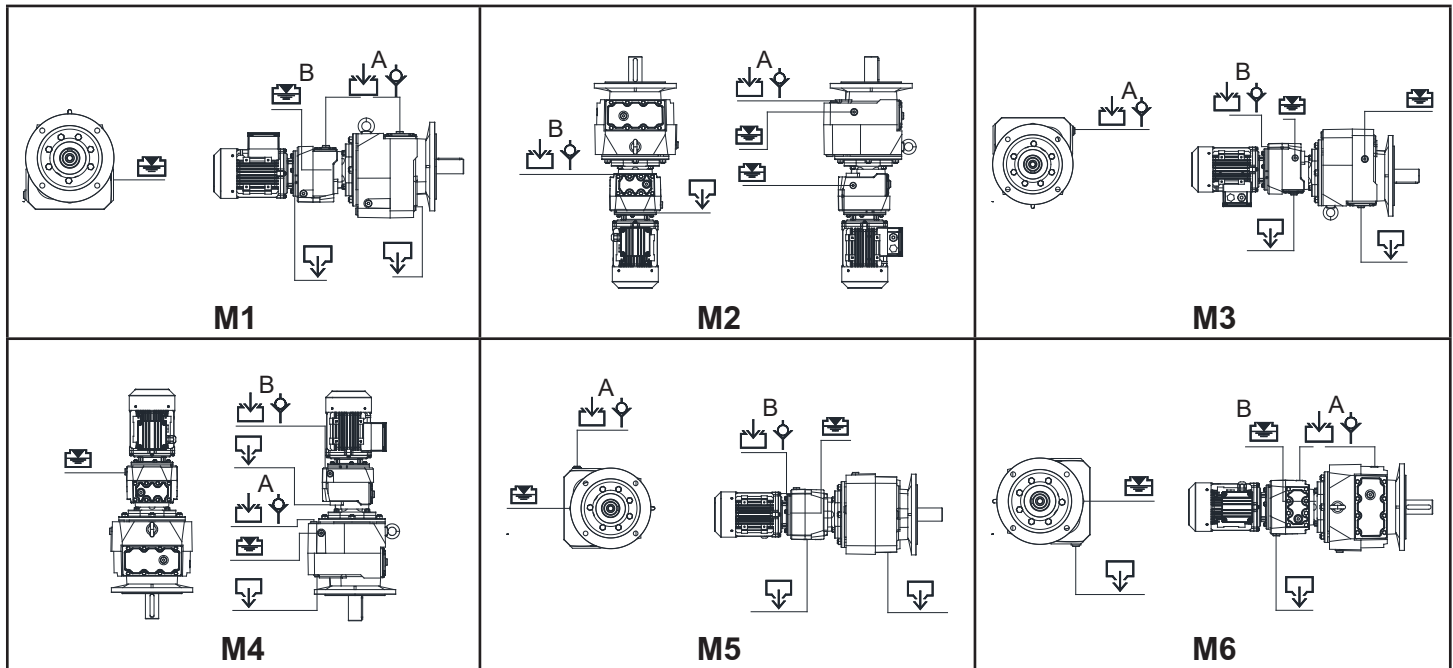

Type	N Series 5-6 Stages Oil Quantities					
	M1 A / B	M2 A / B	M3 A / B	M4 A / B	M5 A / B	M6 A / B
N275	1 / 0.4	1.7 / 0.6	1.5 / 0.5	1.7 / 0.6	1.2 / 0.5	1.2 / 0.5
N285	1.6 / 0.7	2.85 / 0.95	2.5 / 0.7	2.85 / 0.95	2.4 / 0.7	2.4 / 0.7
N575	1.9 / 0.7	3.3 / 0.95	3 / 0.7	3.3 / 0.95	2.6 / 0.7	2.6 / 0.7
N475	4 / 1.2	7.6 / 2.1	7.01 / 2.1	7.6 / 2.1	5 / 1.4	5 / 1.4
N575	6 / 1.2	11.7 / 2.1	10.5 / 2	11.7 / 2.1	7.5 / 1.4	7.5 / 1.4
N675	8.5 / 2	20 / 3.4	18 / 3.1	20 / 3.4	11 / 2.8	10.5 / 2.8
N775	18 / 2	32 / 3.4	28 / 3.1	32 / 3.4	20 / 2.8	20 / 2.8
N875	20 / 2	45 / 3.4	39 / 3.1	45 / 3.4	28 / 2.8	28 / 2.8
N975	50 / 4.5	87 / 8	80 / 7.5	87 / 8	65 / 5.5	65 / 5.5
N276	1 / 0.4	1.7 / 0.55	1.5 / 0.5	1.7 / 0.55	1.2 / 0.4	1.2 / 0.4
N286	1.6 / 0.6	2.85 / 0.8	2.5 / 0.7	2.85 / 0.8	2.4 / 0.7	2.4 / 0.65
N376	1.9 / 0.6	3.3 / 0.8	3 / 0.7	3.3 / 0.8	2.6 / 0.7	2.6 / 0.65
N476	4 / 1.1	7.6 / 2	7 / 1.9	7.6 / 2	5 / 1.3	5 / 1.3
N576	6 / 1.1	11.7 / 2	10.5 / 1.9	11.7 / 2	7.5 / 1.3	7.5 / 1.3
N676	8.5 / 1.9	20 / 3.3	18 / 3	20 / 3.3	11 / 2.6	10.5 / 2.6
N776	18 / 1.9	32 / 3.3	28 / 3	32 / 3.3	20 / 2.6	20 / 2.6
N876	20 / 1.9	45 / 3.3	39 / 3	45 / 3.3	28 / 2.6	28 / 2.6
N976	50 / 4	87 / 7.6	80 / 7	87 / 7.6	65 / 5	65 / 5

Symbols : :Oil filling :Drain plug :Oil level :Vent Plug

Operating Instructions

M/N Series

Mounting Positions



9.4- Mounting Positions

M Series

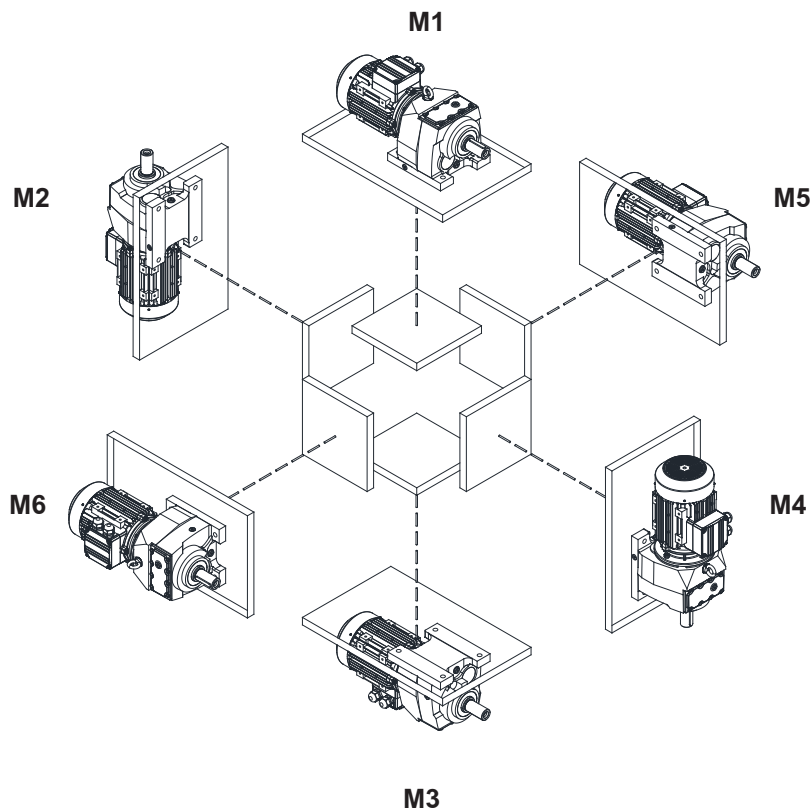

N Series

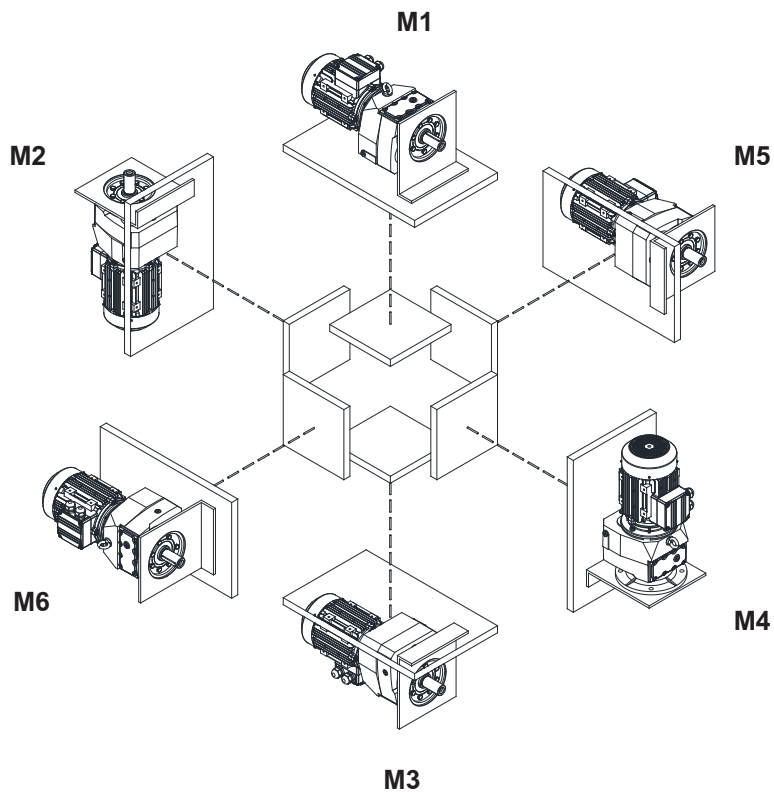

*Indicated mounting positions are determined as reference directional position of the gearbox.
Mounting surfaces are not binding.*



10- Troubleshooting Guide



All instructions recommended below must be carried out by professionally trained mechanics or electricians. JS-Technik must be informed before any modification is made to the gear unit. An oil change can be carried out without consultation. All modifications or executions without the knowledge of JS-Technik are at the user's own risk.

ID	Problem	Observation	Remedy
001	Gearbox Does Not Start Up	You hear no noise and shaft is not turning. You are not using any driver or frequency inverter.	Please Check the voltage supply and frequency of your electric connection. They must be in accordance with the nameplate of the motor. Observe motor manufacturers start up manual. If you are still having issues, go to ID001.
002	Gearbox Does Not Start Up	You hear no noise and shaft is not turning. You are using frequency inverter or driver.	Please observe the frequency inverter/driver manual. Check the motor by connecting the motor directly to the supply voltage to determine if the problem is with the inverter. If you are still having issues, go to ID001.
003	Gearbox Does Not Start Up	You hear some noises, but the motor and the gear shaft are not rotating. You are not using any driver/ frequency inverter or brake motor.	Please Check the voltage supply and frequency of your electric connection. They must be in accordance with the nameplate of the motor. Observe motor manufacturers start up manual. If the same problem persists, the load may be too great for the chosen motor. Loosen the gearbox from the load/torque. If this works, the starting torque is insufficient and higher motor power is needed. For monophaze motors, check the star-ting up condansator and running condansator as well. If you are still having issues, refer to ID100.
004	Gearbox Does Not Start Up	You hear some noises, but the motor and the gear shaft are not rotating. You are using driver or frequency inverter.	Please observe the frequency inverters or drivers manual. To determine the source of the fault, disconnect the motor from the converter. Connect the motor directly to the mains including safety devices. If you are still having issues, go to ID 100.
005	Gearbox Does Not Start Up	You hear some noises, but the motor and the gear shaft are not rotating. You are using a brake motor.	Please check the supply voltage and frequency of the mains connection. These values should be according to the nameplate of the gear motor. Check the operating instructions of the motor manufacturer. Make sure that the brake is in order. Examine the operating instructions of the motor brake. If no solution is found, supply power to the brake individually, for example 198V DC. If a clicking sound is heard, the brake will open. If you do not hear this sound, the brake or the rectifier is damaged. When the brake is active, the motor is supplied with voltage. If the problem persists, the motor may be oversized for the load. Go to ID 003.

Operating Instructions

M/N Series

Troubleshooting Guide



ID	Problem	Observation	Remedy
006	Gearbox Does Not Work in Low Speeds/frequencies.	You are using frequency inverter.	At low speeds, the motors frequency is too low. The parameters of the motor and the inverter must be optimised. The efficiency of the gearbox may be too low at low speed, especially for helical worm gear units. The recommended frequency range is 20-70Hz for helical worm gear units, 10-70 Hz for helical gear units. Use a stronger motor power or change the gear ratio of the gearbox to operate in the recommended frequency range.
007	Transmission does not start in the morning or after the long break	Ambient temperature is below +5° Celsius.	The oil is not in accordance with your working conditions. Change to lower viscosity oils. Refer to the owner's manual for the correct oil selection. Control the engine ambient temperature with a heater. If the problem persists, select an engine with higher power.
008	Gearbox is Heating Up too Much	The gearbox is used below 40 °C ambient temperature.	Measure the surface temperature of the gearbox under full load. If the temperature is below 80°C, it is OK. All ATEX certified gearboxes are designed to operate below 120°C. If the ambient temperature of ATEX gearboxes is above 120°C, be sure to shut down the operation and contact JS-Technik. If a gearbox without ATEX certification is operated above 80°C ambient temperature, check the lubrication type and oil quantity according to the mounting position. Check the mounting position on the gearbox nameplate. If it does not match the current mounting position, go to ID 100.
009	Gearbox is Heating Up too Much	You are using Helical Gear Box. Ambient temp is lower than +40 Celsius	Measure the surface temperature of the gearbox under full load. If the temperature is below 80°C, it is OK. All ATEX certified gearboxes are designed to operate below 120°C. If the ambient temperature of ATEX gearboxes is above 120°C, be sure to shut down the operation and contact JS-Technik. If a gearbox without ATEX certification is operated above 80°C ambient temperature, check the lubrication type and oil quantity according to the mounting position. Check the mounting position on the gearbox nameplate. If it does not match the current mounting position, go to ID 100.
010	Gearbox is Heating Up too Much	Ambient Temp is over +40 Celsius	Standard gearboxes are designed for ambient temperatures below 40°C. If the ambient temperature is above 40°C, a special solution must be used. Please contact JS-Technik GmbH.
011	Gearbox is noisy	Noise is regular and continuous	Check Your moving parts for noise. Disassemble the gearbox and run without load. If you still hear the noise motor bearings or gearbox bearings are defect. Change bearings. Go to ID 100
012	Gearbox is noisy	Noise is random	Check Your moving parts for noise. Disassemble the gearbox and run without load. If the noise is still audible in this case, there may be particles in the oil of the gearbox. Change the oil and check it. If there are metal particles in the oil, the gearbox is damaged. Go to ID100.

Operating Instructions

M/N Series

Troubleshooting Guide



ID	Problem	Observation	Remedy
013	Gearbox is noisy	Regular knocking noise	Check Your moving parts for noise. Disassemble the gearbox and run without load. If you still hear the noise one of the gears inside is defect. Go to ID 100
014	Gearbox is noisy	Regular noise increase and decrease	Check the output shaft for concentricity. Disconnect the gearbox from the machine. If you continue to hear the noise, one of the gears probably has a runout. Follow ID 100.
015	Gearbox is noisy	Gear motor with brake makes irregular noises.	Low random clicking noise may come from the brake disk, which is fine. If the noise level is too high, the brake may be defective or the air gap of the brake disk needs adjustment.
016	Gearbox is noisy	An inverter is used and the volume changes according to the speed.	The parameters of the frequency inverter are not optimised for the frequency range of the motor used. Read the operating instructions of the converter. If the problem persists, possibly change the transmission ratio of the gearbox. Follow ID 100.
017	Oil is Leaking	Oil Leakage from Seal	If the ambient temperature is over 40°C or the operating time without a break is over 16 hours, please fit a breather screw. To do this, read the gearbox bleeding instructions. If it does not help either, a seal may be damaged. Follow ID 100.
018	Oil is Leaking	Oil Leakage from Plug	Check the position of the vent screw. In every assembly position, the vent screw should be in the uppermost position. The screw is sometimes not tight enough. There are some particles sitting under the rubber surface of the screw. Clean and reassemble the screw. If the problem continues, go to ID 100.
019	Oil is Leaking	Oil Leakage from Housing	Find the place where the oil is leaking. It may be that the oil is coming out of the seal or the vent but is flowing over the housing. If this is the case, go to ID018/019. If you are sure that the oil is coming out of the housing, the housing may have a micro-crack. Go to ID 100.
020	Oil is Leaking	Oil Leakage from Cover	The seal under the lid is damaged. Remove the lid and replace the seal. Fit the cover and tighten the cover screws. If the problem is not solved, go to ID 100.
021	Gearbox has regular runout	A torque arm is used	The concentricity error of the gearbox is caused by the connection point. The air gap between the shaft and the hub does not have a proper fit. It has negative influences on the gearbox, especially when using a torque arm.
022	Gearbox has random runout	A torque arm is used.	The concentricity error of the gearbox is caused by the connection point. The air gap between the shaft and the hub does not have a proper fit. It has negative influences on the gearbox, especially when using a torque arm.
023	Motor is heating up	Motor is running over its nominal current	The motor power is not enough or some overload to the motor is possible. The motor may be defect. Go to ID 100
024	Motor is heating up	Ambient is dusty	Check the self-cooling via the motor ribs. If a frequency inverter is used, a forced cooling fan may be necessary at low speed. Go to ID 100.

Operating Instructions

M/N Series

Troubleshooting Guide



ID	Problem	Observation	Remedy
025	Motor is running but Gearbox shaft does not turn	Friction noise occurs	Some elements (gears, shafts) may be defective. Go to ID 10.
026	Gearbox Housing is Defect	You are using chain drive or pinion gear	The radial load or polygon effect of the chain may have caused the damage. Check if mounting screws are loose or if the mounting base is loose. Check if you are using the correct diameter of chain drive and you are not exceeding max. allowed radial load. Check the position of your output element and re-calculate your radial load and check if this fits to the maximum allowed radial load. Goto ID 100
027	Output Shaft is Defect	You are using chain drive or pinion gear	The radial load or polygon effect of the chain may have caused the damage. Check the position of your output element and re-calculate your radial load and check if this fits into the maximum allowed radial load. Go to ID 100.
028	Gearbox is stopping too late	A brake motor is used	Check the brake rectifier, the brake disk, and the wiring of the motor brake.
029	Gearbox is starting too late	A brake motor is used	Check the brake rectifier, the brake disk, and the wiring of the motor brake.
100	Service Required	No self solution found	Please contact JS-Technik. The contact details can be found on each page of these operating instructions. Changes to mechanical parts can only be carried out by JS-Technik or with its consent. The warranty will be invalidated if changes are made without consent.

11- Disposal

If your product is no longer of use and you wish to dispose of it, refer to the instructions here. If you have any questions regarding ecological disposal methods, please consult our service points given on the backside of this manual.

11.1- Disposal of Oil

-Lubricants (oil and greases) are hazardous substances, which can contaminate soil and water. Collect drained lubricant into suitable receptacles and dispose of it according to the valid national guidelines.

11.2-Disposal of the Seals

Remove the sealing rings from the gear unit and remove oil and grease residues. Dispose of the sealings as composite material (metal/plastic)

11.3-Disposal of Metal

If possible, separate the gear material into iron, aluminium and other materials. Dispose of it according to the valid national guidelines.